



36 x 72mm

Features :

Humidity

- ▶ 3 digit LED display
- ▶ RH Sensor input
- ▶ Sensor enclosed with unit
- ▶ ON-OFF control
- ▶ 7A SPDT Relay output
- ▶ 0% - 100% Humidity control range

Temperature

- ▶ 3 digit LED display
- ▶ RTD Input (PT100)
- ▶ ON-OFF / PID control
- ▶ Auto tune / Self tune PID
- ▶ 7A SPDT Relay output

Certifications : **CE** , **IP65**

Technical specifications

Display specifications	
Display	3 Digits 7 Segment LED single white display
LED indication	OUT 1 : RH control ON ; OUT 2 : RTD control ON
Input specifications	
Input signal	RH (HS-A-100), (RTD PT100)
Sampling time	250ms
Input filter (FTC)	0.2 to 10.0 sec
Resolution	0.1 / 1 for RH / RTD inputs
Temperature unit	°C / °F selectable
Humidity unit	%RH
Output specifications	
RH control output	Relay contact (SPDT) : 7A @ 250V AC / 30V DC, Resistive
RTD control output (Relay or SSR user selectable for RTD control)	Relay contact (SPDT) : 7A @ 250V AC / 30V DC, Resistive
Functional specifications	
Control action	PID control with auto tuning , ON - OFF control(For RH: ON-OFF control only)
Proportional band (P)	1.0 to 400.0°C
Integral time (I)	0 to 99.9 min
Derivative time (D)	0 to 999 sec
Cycle time	0.1 to 99.9 sec
Hysteresis width	0.1 to 99.9°C
Manual reset value	-19.9 to 19.9°C
Auxiliary supply specifications	
Supply voltage	90 to 270V AC / DC (AC : 50 / 60)
Power consumption	4 VA max @ 230V AC
Environment specifications	
Temperature	Operating : 0°C to 50°C; Storage : -20°C to 75°C
Humidity (non - condensing)	95% RH
Mechanical specifications	
Mounting	Panel
Weight	93 gms
Sensor Information	
Cable length	1 meter
Dimensions (mm)	52 x 28.8 x 18
Input range	5V DC
Weight	33 gms

HUMIDITY + TEMPERATURE CONTROLLER

HTC405

Terminal connections

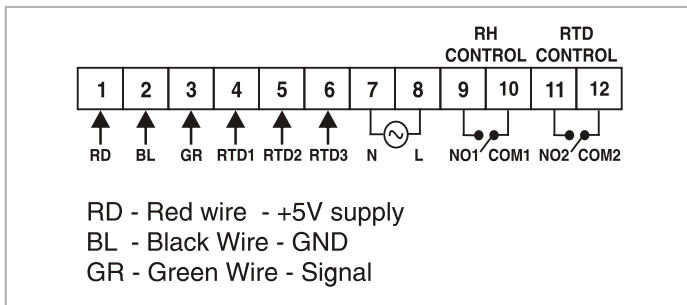

Dimensions (All are in mm)

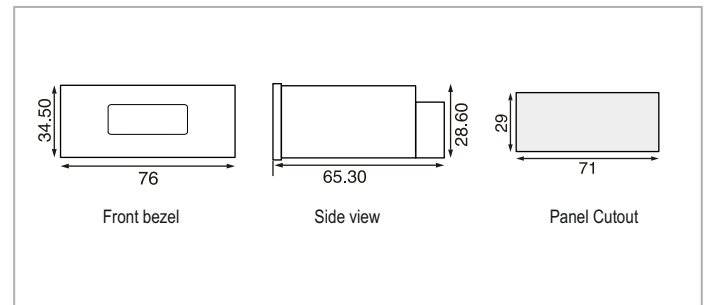

Sensor Dimension (Top & Side)

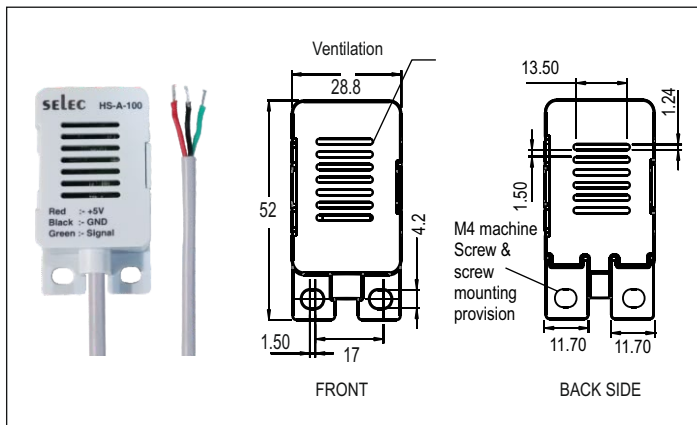

Sensor Dimension (Top & Side)

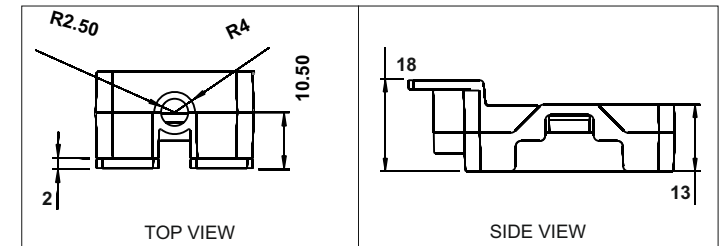

NOTE : Length of the cable can be increased by using compensation cable upto 3 meter. After that accuracy may vary by 1% / Meter.

Humidity Sensor Performance

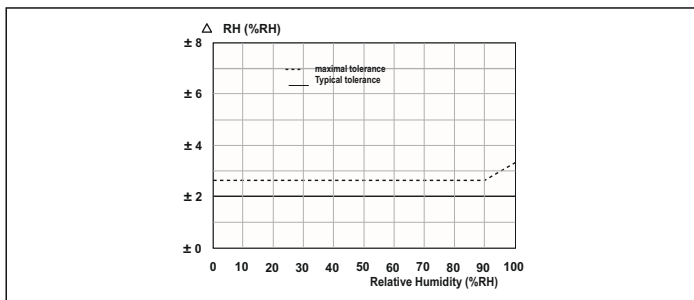

Tolerance of RH at 25°C

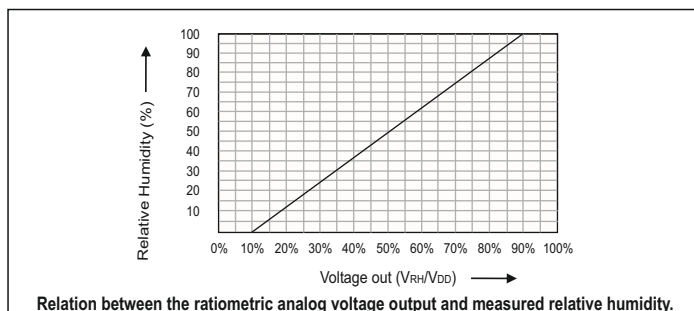

Compliance

Applicable EMI / EMC Standards		
Product Standard : IEC 61326-1		
Category		Standards Compliance
ESD Immunity	IEC 61000-4-2	Level III
Surge Immunity	IEC 61000-4-5	+/- 2 kV common mode, +/- 1 kV differential mode
Radiated Susceptibility	IEC 61000-4-3	Level III, 80 to 1000MHz Level II, 1.4GHz to 2GHz Level I, 2GHz to 2.7GHz
Conducted Susceptibility	IEC 61000-4-6	Level II
Voltage Dips and Interruptions	IEC 61000-4-11	Dips : 0% residual voltage / 1 cycle (Criteria B), 40% residual voltage / 10 cycles 50Hz / 12 cycles 60Hz (Criteria C) 70% residual voltage / 25 cycles 50Hz / 30 cycles 60Hz (Criteria C) Interruptions : 0% residual voltage / 250 cycles 50Hz / 300 cycles 60Hz (Criteria C)
Conducted Emission	CISPR-11	
Radiated Emission	CISPR-11	
Electrical Fast Transient	IEC 61000-4-4	Level III

Ordering information

Product Code	Input	Control Output		Supply Voltage	Certification
		Output 1	Output 2		
HTC405	RH+RTD	RELAY (7A)	RELAY (7A)	90 to 270V AC / DC	CE